



MODEL

M601

Solar-Powered LED Marine Lanterns



Carmanah's Model M601 is the most versatile, no-maintenance solar marine lantern available with 2 nautical miles visibility. Available in all IALA chromaticity colors. Easy, on-site programming capabilities. Installs in minutes.

LIGHT OUTPUT AND OPERATION

Visibility ^{1,2}	2 nautical miles (3.6 kilometers)
Peak intensity (360-degree average, green LEDs)	~11 Candela
IP68 waterproof rating	Yes
Temperature range	-40° to +176° F (-40° to +80° C)
Vertical divergence	7°
Autonomy (flashing) at full charge	300 hrs
Horizontal output	360°
Available LED color	Red, green, amber or white
Colored lens option	Yes
Flash patterns	250+
Programmable (infrared)	Yes

CONSTRUCTION

Solar panels	Mono-crystalline potted with UV-protected polyurethane and domed for higher efficiency
Light source	LED
Lifespan of LEDs	Up to 100,000 hours
Lens material	Polycarbonate
Battery (average 5-year life)	Non-replaceable
Battery amp-hour	5Ah
Battery venting	Vent at the bottom of the lantern
Sealing	Self-contained unit, potted with polyurethane
MICROSOURCE®	Yes
Scheduled maintenance	None for 5 years
Mounting options	3 bolt
Weight	4.85 lbs (2.2 kg)

TRADEMARKS, PATENTS AND APPROVALS

WEEE compliant	Yes
RoHS compliant	Yes
CE Approval	As per EN 60945:1997
Trademarks and Patents	US Patents: 6,573,659 and 6,013,985 Other Patents Pending



Clients

Australian Maritime Systems
 Brazilian Naval Commission
 Canadian Coast Guard
 CETMEF, France
 Indian Port of Kandla, India
 Maritime and Port Authority of Singapore
 NOAA – National Data Buoy Center
 Panama Canal
 Suez Canal, Egypt
 Trinity House Lighthouse Service, UK
 United States Coast Guard
 Vancouver Port Authority

Carmanah Technologies Corporation

Building 4-203 Harbour Rd.
 Victoria, BC V9A 3S2
 Toll Free: +1.877.722.8877
 (US & Canada)
 Worldwide: +1.250.380.0052
 Fax: +1.250.380.0062
 Email: info@carmanah.com

CHANGE THE WORLD WITH US™

Solar-Powered LED Marine Lanterns Model M601



Side View

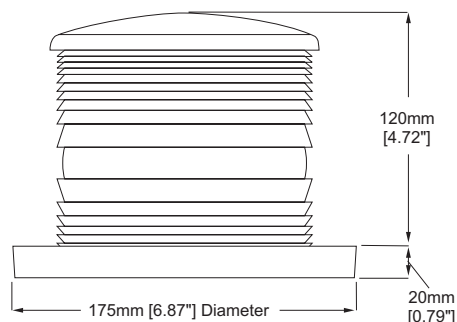

Top View

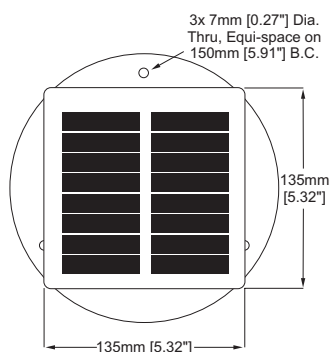

Accessories

Infrared Programmer



Security Bolt



Bird Deterrent



Mounting Plate

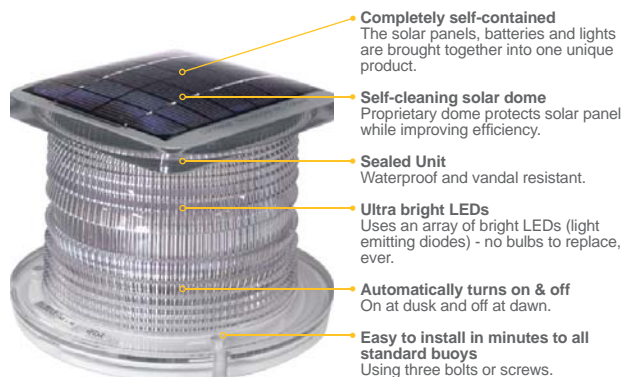

Carmanah's Model M601 solar marine lantern is designed for long-time, low-maintenance use for a variety of aids-to-navigation applications. Solar-powered and completely self-contained, this cost-effective marine lantern utilizes the most advanced LED technology, high-grade batteries and mono-crystalline solar panels. The Model M601 solar marine lantern offers:

- **Maximum capacity with minimal life-cycle cost** – operates up to 5 years maintenance free
- **Field-proven durability** – technology tested over 15 years
- **Third-party testing** – passed extensive shock and vibration testing
- **IP68 certification** – tested to higher levels of water ingress protection standards
- **Vandal and theft resistant design** – high quality construction and mounting hardware
- **Patented technology** – innovative LED technology and energy management system
- **Dependable illumination** – a 10-year effective lifespan with LEDs operating up to 100,000 hours

The Model M601 is also:

- Manufactured in accordance with ISO 9001:2000 Quality Assurance Standards
- RoHS and WEEE certified
- Engineered to meet requirements of the USCG in 33 CFR part 66 for Private Aids to Navigation

¹ Transmissivity of 0.74

² Actual range is dependant on flash pattern, intensity, and LED color.



Toll Free Canada & US: 1.877.722.8877 • carmanah.com • Worldwide: +1.250.380.0052