

Model A702

Three Mile¹ Aviation Light

SOLAR AVIATION LIGHT

Typical Applications

- Runway edge lighting
- Threshold lighting
- Obstruction lighting
- Heli-pad lighting
- Telecommunication towers
- Wind energy masts

Features & Benefits

- Provides up to five years of operation with no maintenance, servicing or infrastructure costs
- Installation takes minutes and requires minimal technical expertise
- Easily mounted to standard frangible coupling
- Completely self-contained and sealed against environmental conditions
- Extremely rugged, waterproof and vandal resistant
- Distance of visibility up to 3 miles (5.4 kilometers)
- Will charge under nearly all weather conditions
- Up to 150 hours of operating capacity from a full charge
- Any flash pattern available from the factory. Can also be programmed by the user using optional infrared remote control
- Features three, four and five-bolt mounting patterns
- Replaceable battery packs available
- Manufactured under ISO:9001 Quality Assurance Practices
- Available in red, green, amber, white and blue
- 30 day satisfaction guarantee and three year warranty

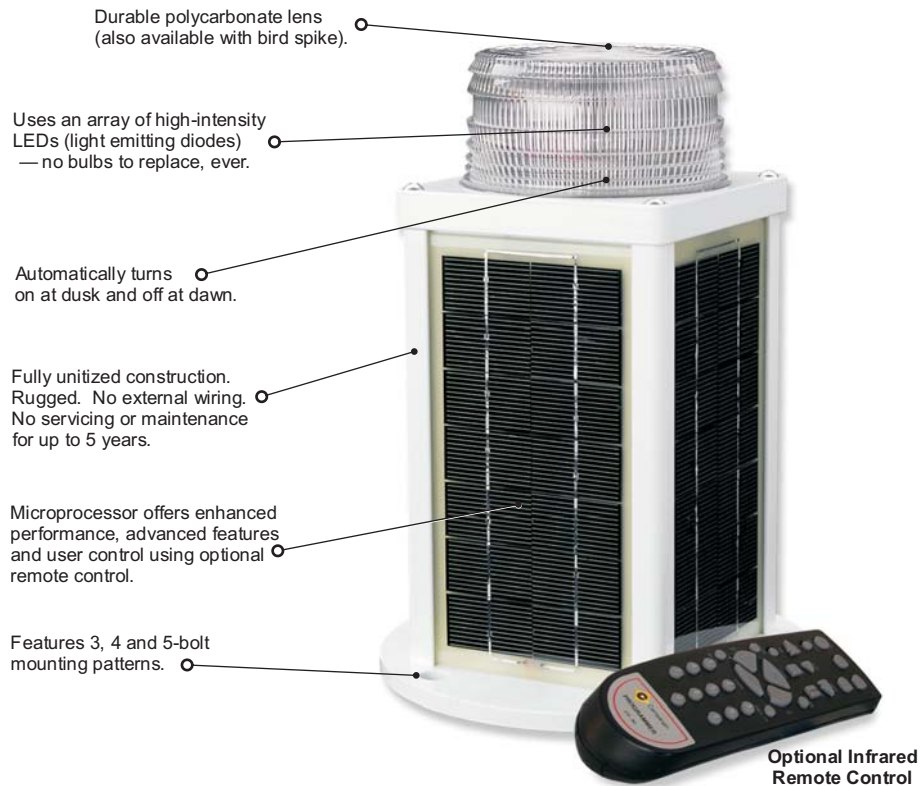

The Carmanah Model A702 is the world's most advanced, fully-integrated, solar LED three mile¹ (5.4km) aviation marking light. It installs in minutes and requires no maintenance or servicing for up to five years.

Typical Applications

Initially implemented for expedited airfield lighting with the US Air Force and the US Army, the 700 Series are the first solar powered LED aviation lights to be used for fixed wing operations at remote airfield landing strips and expedited airfields.

Fully-integrated, self-contained and watertight, the 700 Series are used for temporary and permanent runway edge lighting, obstruction lighting and heli-pad lighting applications.

The A702 is the larger version of the two models available in the 700 Series; it is intended for use in regions where daily solar illumination is less than 1.5 hours of winter sunlight.

The Technology

Utilizing an innovative combination of solar and LED technology, the 700 Series lights charge during the day, even under cloudy conditions, and turn on automatically at night. Instead of traditional incandescent bulbs, the 700 Series use durable, high-intensity light emitting diodes (LEDs), which have a lifespan of up to 100,000 hours. Therefore, other than replacing the battery packs approximately every 5 years, the 700 Series are designed to operate flawlessly with no additional servicing or maintenance.

30-Day Risk-Free Evaluation

Order a Model A702 today and evaluate the product's quality, performance and reliability for yourself. If you are not fully satisfied, you can return the unit within 30 days for a refund of the purchase price.

No external wiring, no battery or bulb replacement, no maintenance, no worries...



Carmanah

THE LEADER IN SOLAR LED LIGHTING SOLUTIONS



Model A702

Three Mile¹ Aviation Light

Top View

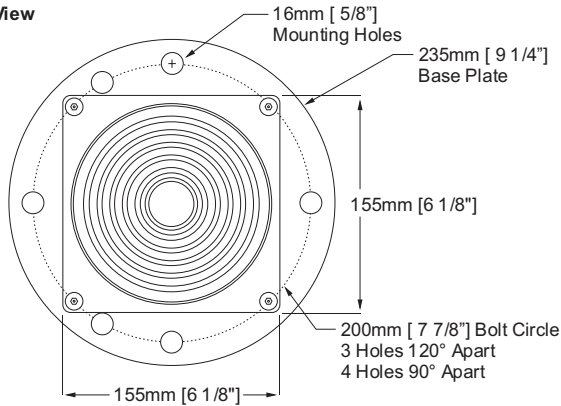

Side View

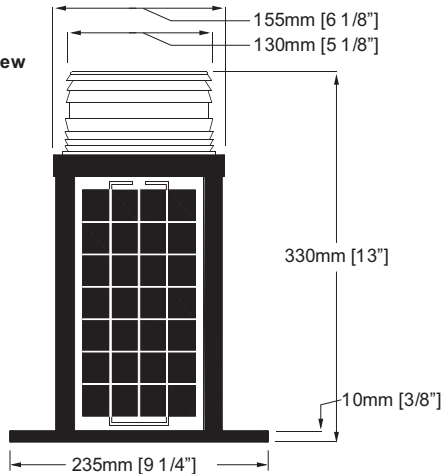

Optional Infrared Remote Control



SPECIFICATIONS

LIGHT OUTPUT

	FLASHING ²	STEADY ON
Effective Intensity (Transmissivity constant of 0.74) Green, Red, Amber, White, Blue	~ 18 Candela	~ 6 Candela
Nominal Night Range (Employs Method of Schmidt-Clausen) Green, Red, Amber, White, Blue	~ 3.2 NM	~ 2.2 NM
Vertical Divergence	6 degrees	
Horizontal Output	360°	

OPERATION

Minimum Autonomy ³	300 Hours	150 Hours
Minimum Equivalent Peak Sun Hours to Maintain Minimum Autonomy	1.5 Hours	3 Hours
Latitude Range ⁴	55° S to 55° N	
On / Off Level	70 / 100 Lux	
Illumination Technology	16 or 24 LEDs, depending on color	
Lifespan of LEDs ⁵	Up to 100,000 Hours	
Available Standard Flash Patterns (Custom patterns available)	208 including "steady-on"	

CONSTRUCTION

Solar Panel	Mono-Crystalline
Battery	Potted with UV-protected polyurethane
Lens Material	Pure-lead thin plate with starved-electrolyte
Battery Venting	Polycarbonate
Sealing	Vent at the bottom of the lantern
Weight	Self-contained unit, sealed with gaskets
	7.75 kg (17 lbs)

ENVIRONMENTAL and ELECTRICAL

Temperature Range ⁶	-40° to +80° C (-40° to 176° F)
Waterproof	As per IP67 (NEMA 6)
CE Approval	As per EN 60945:1997

TRADEMARKS and PATENTS

Trademarks and Patents

US Patents: 5,782,552 & 6,013,985
European Patent Application: 96925627.0
Other Patents Pending

¹ Actual range is dependant on flash pattern, intensity, and LED color.

² All "Flashing" light specifications are based on 100% intensity setting at 12.5% duty cycle (code 064 - 15 flashes per minute).

³ Actual figures for autonomy depend on the intensity level setting.

⁴ Lights will function reliably at higher latitudes than 55° North or South if intensity/autonomy is properly adjusted to suit operating environment by an Authorized Carmanah Representative.

⁵ Amber, Red, Green: ~14 years to 80% of original effective intensity when operated at night with a 12.5% duty cycle.

⁶ Consistent ambient temperatures above +25°C (+77°F) may affect overall battery life. Temperatures above +60°C (+140°F) may affect output.

All specifications are subject to change without notice.



THE LEADER IN SOLAR LED LIGHTING SOLUTIONS



REPRESENTED BY

Allister Wilmott

Sales & Marketing
awilmott@carmanah.com

Carmanah Technologies Inc.

Building 4, 203 Harbour Road
Victoria, British Columbia
Canada V9A 3S2

Toll-Free: 1-877-722-8877
(North America)

Worldwide: (250) 380-0052
General Fax: (250) 380-0062
Sales Fax: (250) 389-0040

Web Site: www.solarairportlights.com
www.obstructionlights.com

Carmanah is a Canadian public corporation - TSX VE: CMH

Carmanah is an ENERGY STAR® partner.

© 2004 Carmanah Technologies Inc.
"Carmanah" and Carmanah logo are trademarks of Carmanah Technologies Inc.
Document: r05-141204