

Model A702T

Three Mile¹ Threshold Light

SOLAR THRESHOLD LIGHT

Typical Applications

- Short Airfield Lighting Systems
- Military Expedited Airfields
- General Aviation Airports
- Displaced Runway Thresholds
- Private Airstrips
- Remote Runways

Features & Benefits

- Uses split red/green LED array
- Night vision goggle (NVG) compatible
- Provides up to five years of operation with no maintenance, servicing or infrastructure costs
- Installation takes minutes and requires minimal technical expertise
- Easily mounted to standard frangible coupling
- Completely self-contained and sealed against environmental conditions
- Extremely rugged, waterproof and vandal resistant
- Distance of visibility up to 3 miles (5.4 kilometers)
- Will charge under nearly all weather conditions
- Up to 150 hours of operating capacity from a full charge
- Can be programmed by the user via optional infrared remote control
- Features three, four and five-bolt mounting patterns
- Replaceable battery packs available
- Manufactured under ISO: 9001 Quality Assurance Practices
- 30 day satisfaction guarantee and three year warranty

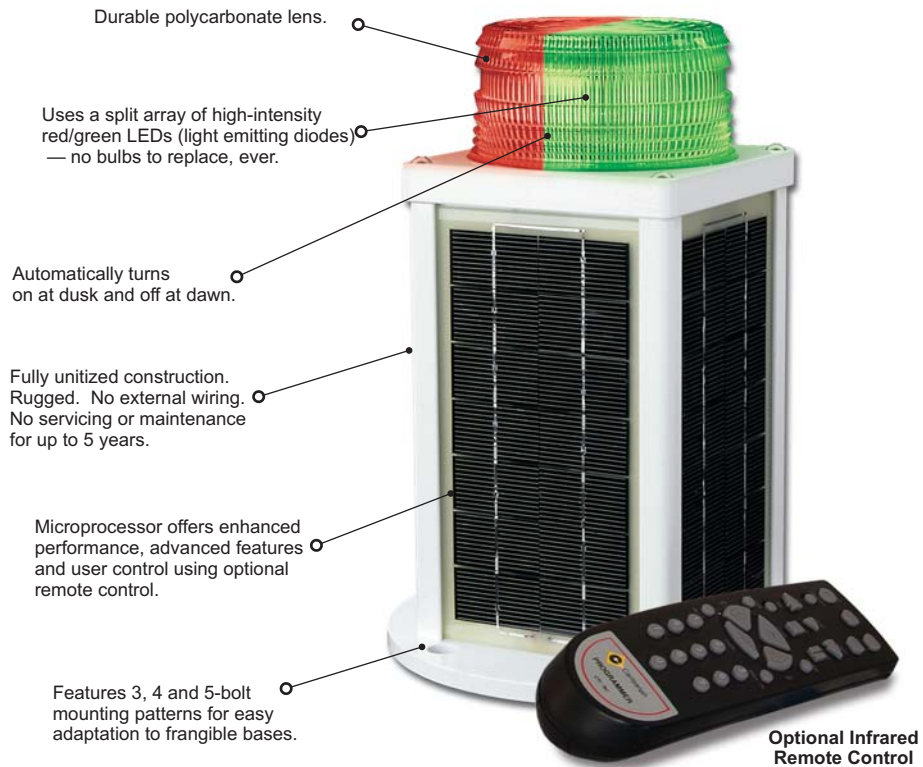

The Carmanah Model A702T is the world's most advanced, fully-integrated, threshold light. Using solar-power and LEDs (light emitting diodes), it installs in minutes and requires no maintenance or servicing for up to five years.

Typical Applications

Initially implemented for expedited airfield lighting with the US Air Force and the US Army, the 700 Series are the first solar powered LED aviation lights to be used for fixed wing operations at remote landing strips and expedited airfields.

The Model A702T is fully-integrated, self-contained and completely watertight. It is designed for permanent, temporary and expedited runway threshold edge lighting applications.

The A702T features a unique split red/green LED array with a clear lens for precision illumination and optimal brightness.

With 4 solar panels and significant power storage capacity, the A702T is designed to operate reliably at any location featuring a minimum of 1.5 hours of winter sunlight.

No external wiring, no battery or bulb replacement, no maintenance, no worries...

The Technology

Utilizing an innovative combination of solar and LED technology, the 700 Series lights charge during the day, even under cloudy conditions, and turn on automatically at night. Instead of traditional incandescent bulbs, the 700 Series use durable, high-intensity light emitting diodes (LEDs), which have a minimum expected lifespan of 100,000 hours. Other than replacing the battery packs approximately every 5 years, the 700 Series are designed to operate flawlessly with no additional servicing or maintenance.

30-Day Risk-Free Evaluation

Order a Model A702T today and evaluate the product's quality, performance and reliability for yourself. If you are not fully satisfied, you can return the unit within 30 days for a refund of the purchase price.

Model A702T

Three Mile¹ Aviation Light

Top View

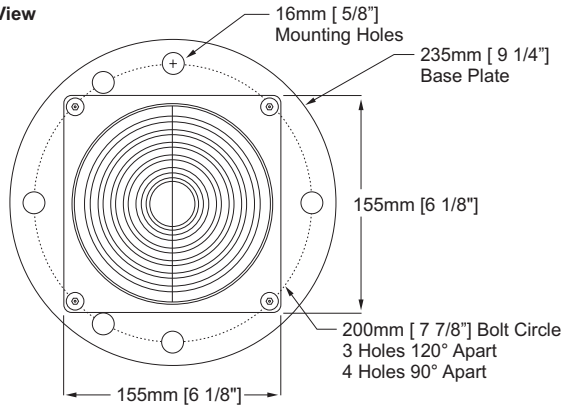

Side View

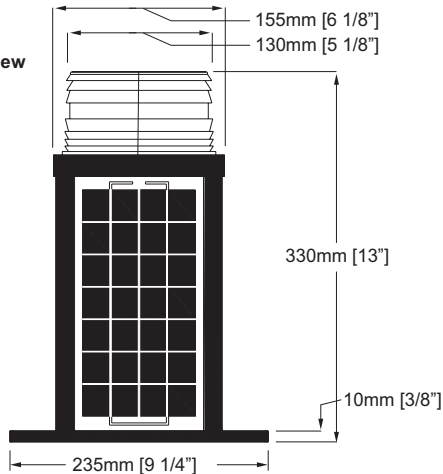

Optional Infrared Remote Control



SPECIFICATIONS

LIGHT OUTPUT

	STEADY ON
Effective Intensity (Transmissivity constant of 0.74)	
Green	~ 10 Candela
Red	~ 6 Candela
Nominal Night Range (Employs Method of Schmidt-Clausen)	
Green	~ 2.6 NM
Red	~ 2.2 NM
Vertical Divergence	6 degrees
Horizontal Output	360°

OPERATION

Minimum Autonomy ²	150 Hours
Daily Equivalent Peak Sun Hours to Maintain Minimum Autonomy	1.5 Hours
Latitude Range ³	55° S to 55° N
On / Off Level	70 / 100 Lux
Illumination Technology	Split Red/Green LED Array
Lifespan of LEDs	Expected minimum 100,000 Hours
Available Standard Flash Patterns (Custom patterns available)	208 including "steady-on"

CONSTRUCTION

Solar Panels	Mono-Crystalline
Battery	Pure-lead thin plate with starved-electrolyte
Lens Material	11.2 Watts
Battery Venting	Polycarbonate
Sealing	Vent at the bottom of the lantern
Weight	Self-contained unit, sealed with gaskets
	7.75 kg (17 lbs)

ENVIRONMENTAL and ELECTRICAL

Temperature Range ⁴	-40° to +80° C (-40° to 176° F)
Waterproof	As per IP67 (NEMA 6)
CE Approval	As per EN 60945:1997

TRADEMARKS and PATENTS

Trademarks and Patents	US Patents: 5,782,552 & 6,013,985 European Patent Application: 96925627.0 Other Patents Pending
------------------------	---

¹ Actual range is dependant on flash pattern, intensity, and LED color.

² Actual figures for autonomy depend on the intensity level setting.

³ Lights will function reliably at higher latitudes than 55° North or South if intensity/autonomy is properly adjusted to suit operating environment by an Authorised Carmanah Representative.

⁴ Consistent ambient temperatures above +25°C (+77°F) may affect overall battery life. Temperatures above +60°C (+140°F) may affect output.

All specifications are subject to change without notice.

REPRESENTED BY

Allister Wilmott

Sales & Marketing
 awilmott@carmanah.com

Carmanah Technologies Inc.

Building 4, 203 Harbour Road
 Victoria, British Columbia
 Canada V9A 3S2

Toll-Free: 1-877-722-8877
 (North America)

Worldwide: (250) 380-0052
 General Fax: (250) 380-0062
 Sales Fax: (250) 389-0040

Web Site: www.solarairportlights.com
www.obstructionlights.com

Carmanah is a Canadian public corporation - TSX VE: CMH

Carmanah is an ENERGY STAR® partner.

© 2004 Carmanah Technologies Inc.
 "Carmanah" and Carmanah logo are trademarks of Carmanah Technologies Inc.
 Document: r05-141204